

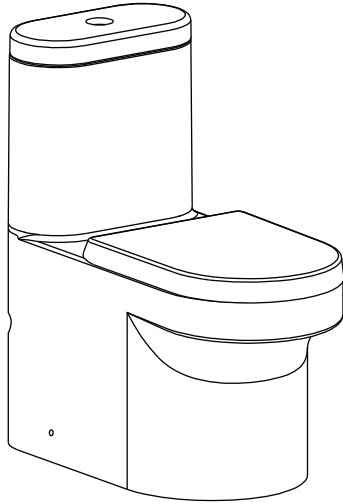

39075001

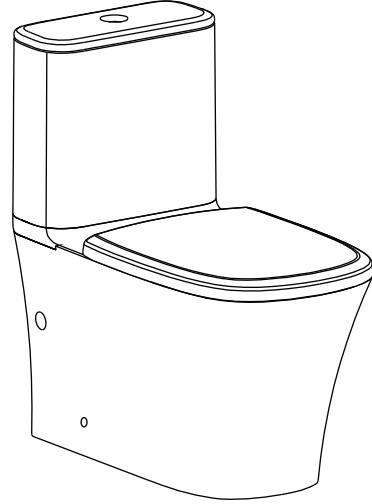

39310000



39119001

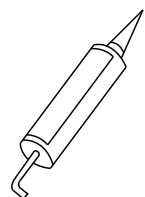
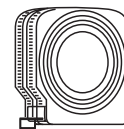
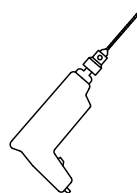
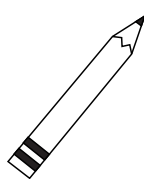
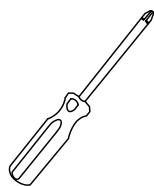
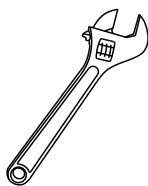
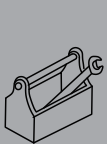
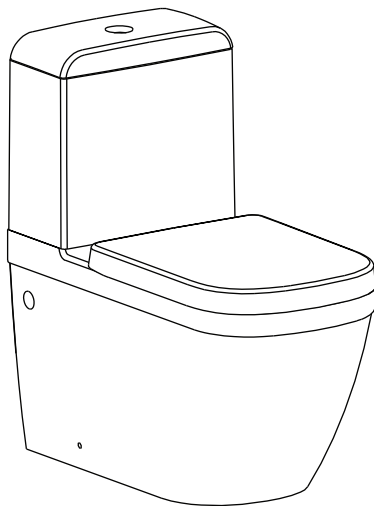

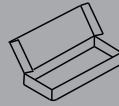

39075001



○ — 2X

● — 2X

— 2X

— 2X

— 2X

— 2X

— 2X

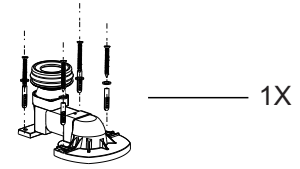
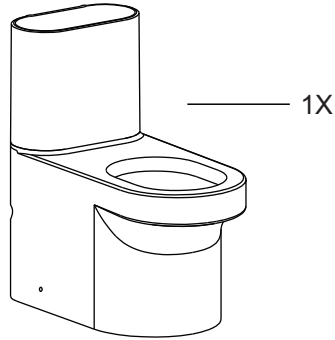
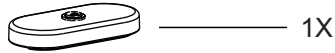

39310000



○ — 2X

● — 2X

— 2X

— 2X

— 2X

— 2X

— 2X

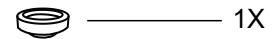
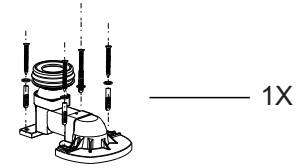
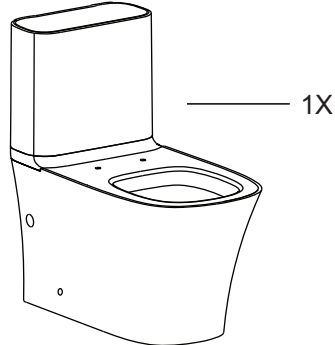
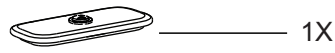

39119001



○ — 2X

● — 2X

— 2X

— 2X

— 2X

— 2X

— 2X

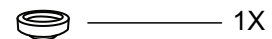
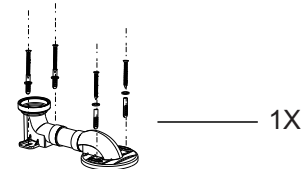
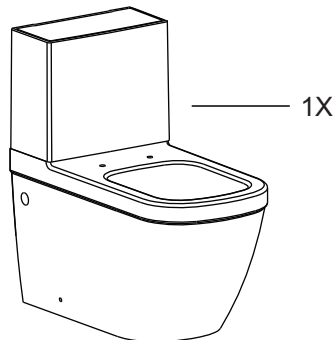



39075001

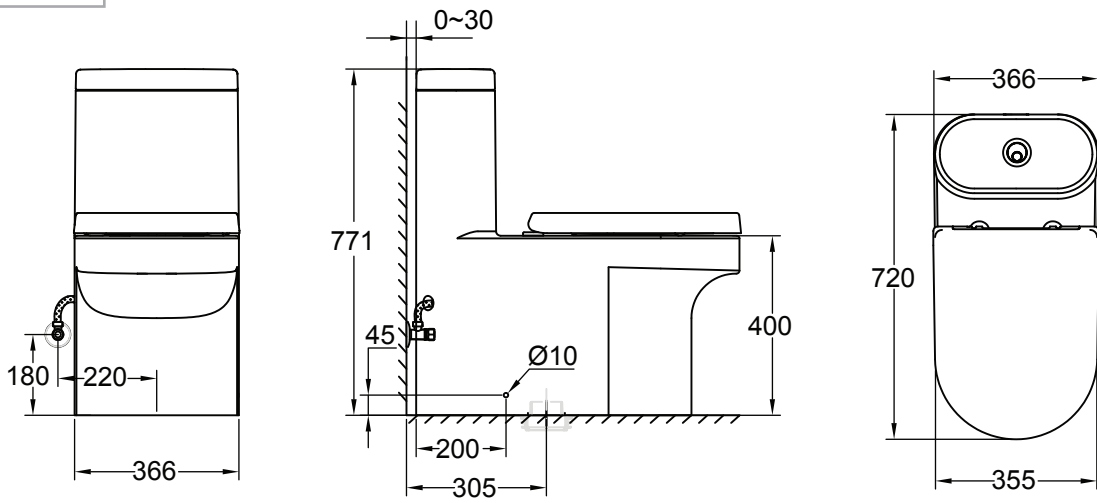

39310000

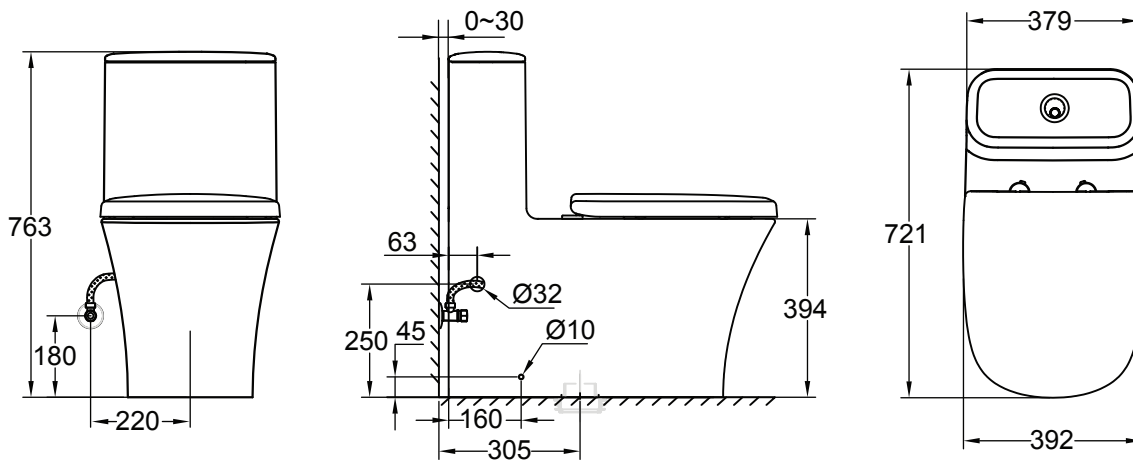

39119001

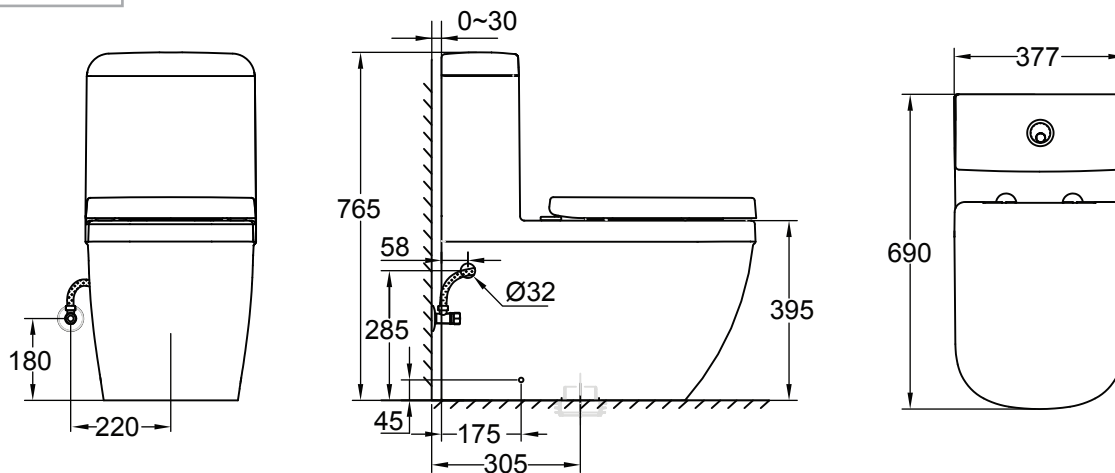

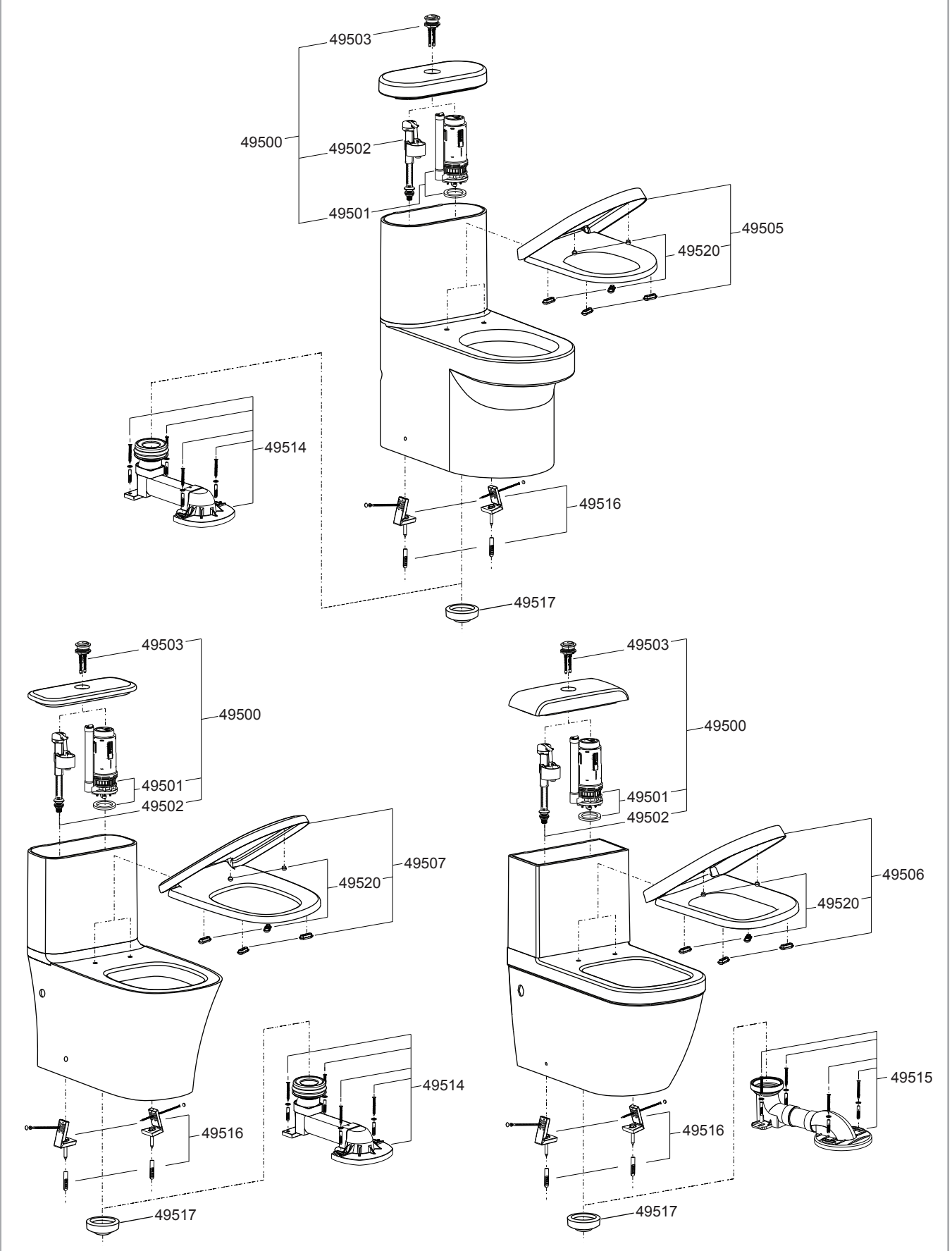

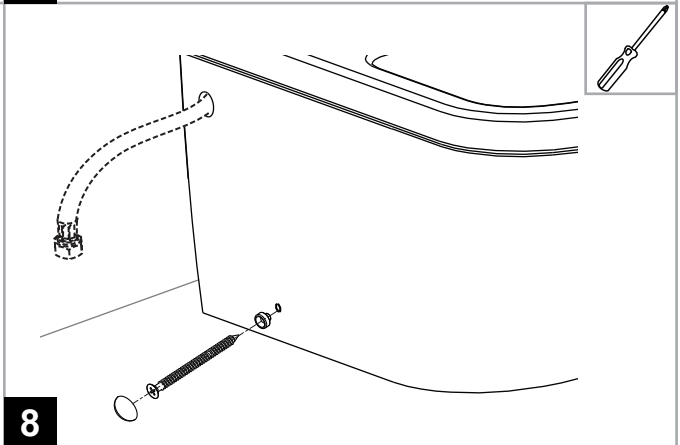
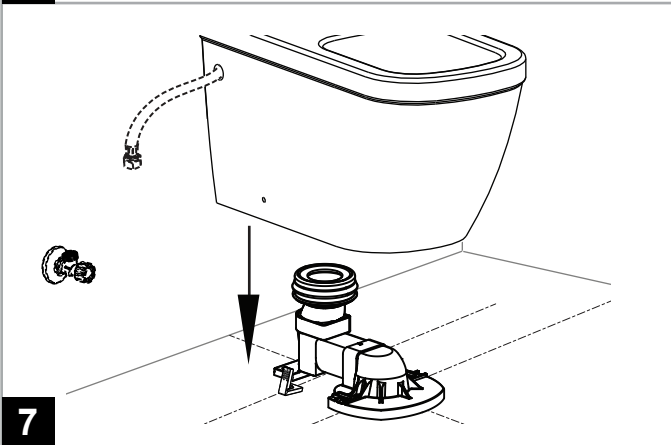
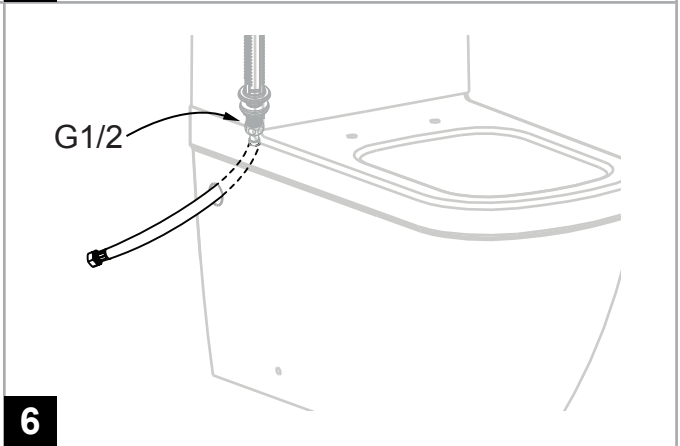
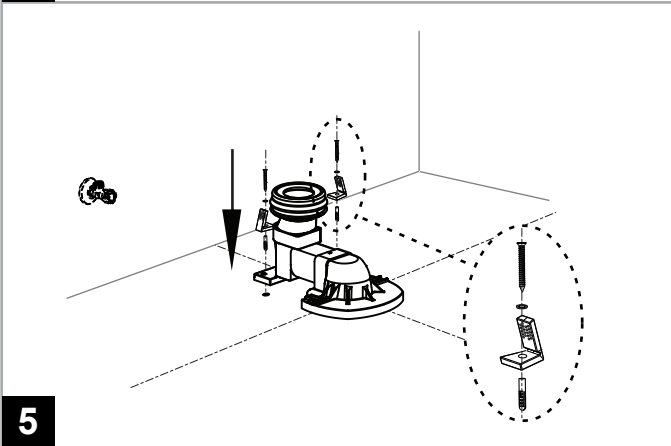
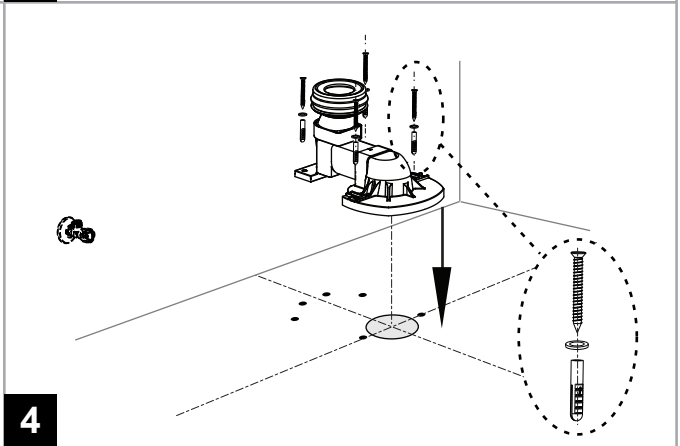
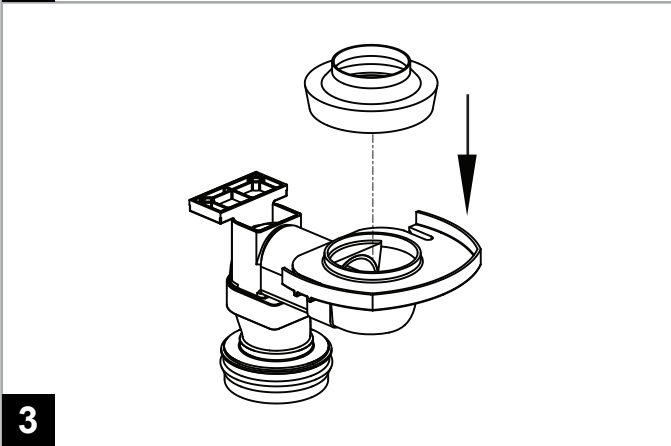
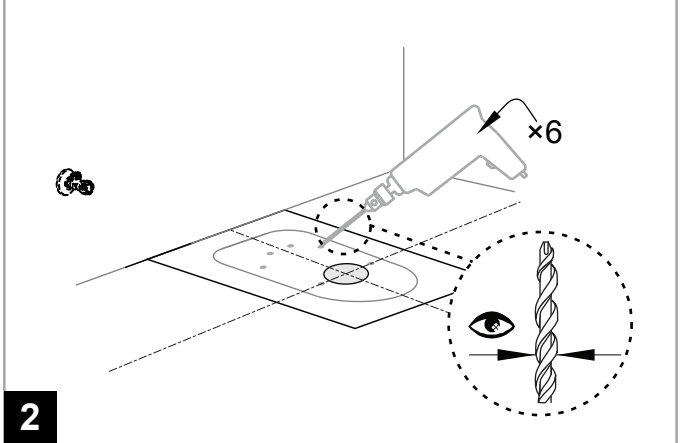
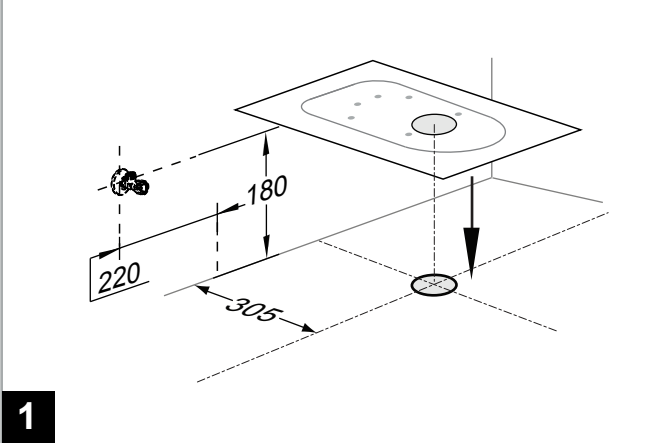

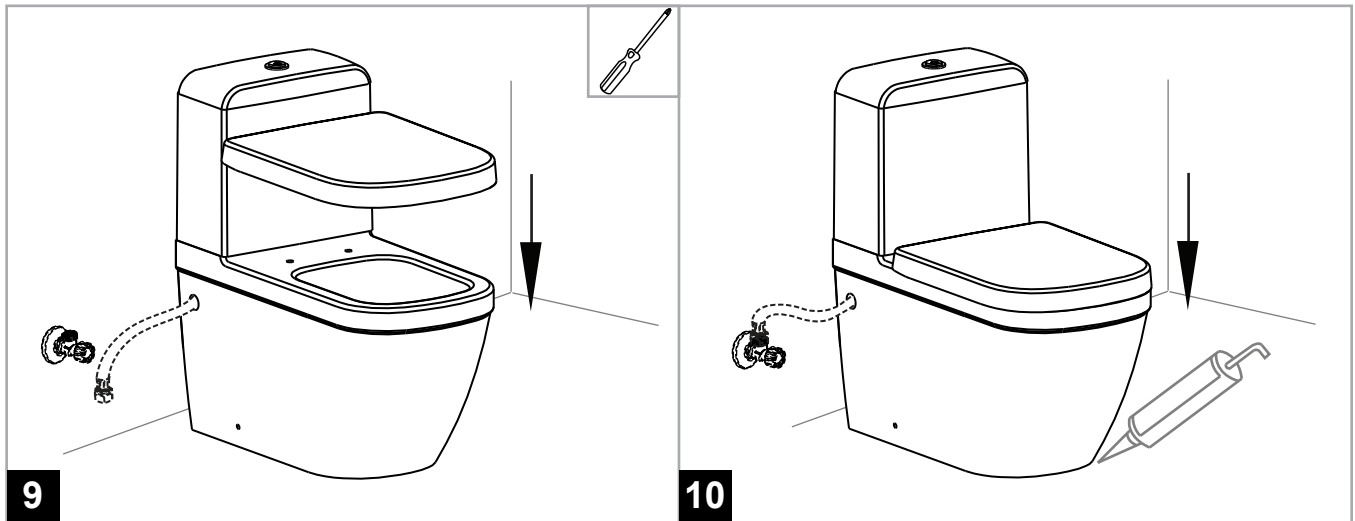

故障排除表

现象	原因	处理措施
冲水不良	水压过低	正常水压必须大于或等于20psi (0.14mpa)
	冲水按钮或手柄损坏	更换按钮或手柄
	水位线比要求的低	重新调整水位至正确水位线
	排水阀链条太松，不能完全抬起拍盖	调整冲水阀链条长度
	水箱有沉淀物	清理水箱，停止使用水箱清洁剂
	座便器水道或圈沿孔堵塞	清理冲水道及清洁圈沿孔
	座厕排污水道或排污管堵塞	清理堵塞
漏水	进水管安装不良，导致漏水	检查水管密封圈，重新安装
	进水水压过高	适当关小止水阀
	水位过高，高于水件溢水口	重新调整水位至正确水位线
	水箱密封圈安装不良或损坏	重新安装水箱，调整密封圈或者更换
	进水阀浮筒周围有外来物卡住	清除外来物或调整进水阀安装位置
	进水阀止水浮筒内可能有脏物	卸下浮筒，清洁后重新安装或更换进水阀
	排水阀拍盖可能变形，或橡胶密封圈密封不良或老化	更换或调整出水阀橡胶密封圈或根据需要更换排水水阀
	出水阀拍盖装置，收得太紧导致拍盖无法关严	调节排水阀链条
	排污管堵塞	清理排污管内的堵塞物
排污管密封圈未密封完全	根据安装说明书检查排污管密封，重新安装或者更换新密封蜡圈	
水箱注水时间过长或噪音过大	进水阀入水口或供水管堵塞	清理进水阀进口滤网或供水管滤网

安装之前

感谢阁下选用我们的产品，我们的产品多年来一直是优良质量的标志。为了有助于安装顺利进行，请您在开始安装之前仔细阅读这些指南，也请查阅推荐的工具和材料表；小心打开您的新产品。高仪公司一贯奉行不断提高和改善其产品设计与性能的政策，并保留对其产品规格、包装更改的权利，届时，恕不另行通知。

本指南仅供安装和使用做参考，产品以实物为准。

所有的安装程序必须严格遵从当地的卫浴和建筑法则。

此安装说明书只针对座厕部分的安装予以简要说明，水箱配件及盖板的安装请分别参见相应的安装说明书。

准备工作

- 小心查看您的新产品，并检查产品是否完好，配件是否完整。
- 参考尺寸图，检查安装尺寸，确保能够正确安装。
- 如果有旧的座便器，应在关掉水源后，再拆除座便器并清洁地面。如果是新安装座便器，请切断水源并清洁地面。
- 软管长度需不小于450毫米。
- 如果不马上安装新座便器，请用干净的物品堵住排污管下水口，以防外来物件掉落在排污管内，堵塞管路。
- 地面应平整。如不平整，可能会造成座便器安装后开裂的后果。
- 尺寸图未标注单位的统一默认为毫米。
- 图示中，虚线表示的配件已安装好。

▲ **警告：易碎产品。小心轻放。**

▲ **警告：严禁使用水泥固定座厕。**

- 水效等级参考表，标准号：GB25502-2017
- 39075001，用水量：3/4.8升，额定用水效率等级：1级；
- 39310000，用水量：3/4.8升，额定用水效率等级：1级。
- 39119001，用水量：3.5/5升，额定用水效率等级：1级。

用户须知

- 当您清洁座厕时，请使用温和的肥皂水，然后用清水清洁并使用软布擦干。避免使用洗洁精、消毒剂，避免在气雾剂容器内清洁产品。杜绝使用颗粒状的清洁粉末或者在座厕上放置粗糙的座垫。一些浴室的化学药品和化妆品可能有害于座厕的光洁。
- 请不要用重力撞击陶瓷，防止破损漏水。
- 请不要在0°C以下的环境中使用。
- 水箱内水位不到标准水位线，会影响冲洗效果。
- 水压偏大时，请适当关小进水角阀，以免进水角阀软管脱落。
- 如果你居住地方的水质是硬性的，你必须保持冲水清洁，令座便器冲水正常。每星期应最少使用坐便清洁剂清洁一次，用长把手的刷子清洁冲水孔，并尽量伸入排污管洗刷，防止矿物质积聚。
- 根据盖板安装说明书安装盖板。
- 产品尺寸图仅供参考，产品具体尺可能在公差范围尺寸内有所变化。

▲ **不要在水箱内使用清洁剂，含氯（次氯酸钙）的清洁剂会严重破坏水箱内的装置，从而引起渗漏或楼宇结构损坏。高仪公司不会对由于使用此种含氯（次氯酸钙）的清洁剂而损坏水箱内装置负责或赔偿。**

▲ **请勿使用钢丝球等硬质材料擦洗产品表面，特别是产品商标处。**

▲ **矽胶的干燥时间不低于24小时。**

TROUBLESHOOTING CHART

SYMPTOMS	PROBABLE CAUSES	CORRECTIVE ACTION
Poor flushing performance	Water pressure is too low.	Normal water supply pressure must be at least 20 psi (0.14 mpa).
	Flush handle or button is broken.	Replace flush handle or button.
	Water level in tank is below prescribelevel.	Set to prescribed level.
	Outlet valve chain is loosening, can not put up the flapper.	Adjust the length of chain.
	There is some sediments in the tank.	Clean the tank and cease using the cleanser.
	Toilet passageway or rim hole is blocking.	Clean the passageway or rim hole.
	Drain outlet of the toilet or trapway is blocking.	Clean the passageway.
Water overflow	Water supply hose installation badness.	Check the seal ring of the water supply hose and reinstallation.
	The water pressure is too high.	Turn angle valve down properly.
	Water level in tank is higher than overflow pipe.	Adjust the cylinder to maintain the water at the prescribed level.
	Tank seal ring installation badness or broken.	Reinstallation tank, adjust the seal ring or replace.
	There is sand or debris around the float.	Clean the sand or debris.
	Sand or debris may be lodge in the water control mechanism.	Shut off water supply valve. Remove float. Clean and reassemble, or replace outlet valve.
	The flapper of flush valve is be out of shape, or the rubber seal disk are worn or deformed.	Replace seat, rubber seal disk, or complete assembly, as needed.
	Flush valve string is too tight, holding the flush valve open.	Replace outlet valve.
	Trapway is blocking.	Clean the trapway.
	The wax ring is not sealed completely.	Check the wax ring leakproofness according to the installation manual, reinstall or replace the wax ring.
Fill in long time or noisy	Plugged valve inlet or supply line.	Clean the filter of inlet valve.

BEFORE YOU BEGIN

Thank you for selecting our products, products which have been the benchmarks of fine quality for years. To help ensure that the installation process will proceed smoothly, please read these instructions carefully before you begin. Also, review the recommended tools and materials list; carefully unpack and examine your new plumbing fixture.

Grohe Company always execute the policy of unceasingly enhancing and improving its product's design and performance. We reserve the right to make any changes on product specifications, packaging and availability at any time without prior notice. This guide is used for installation and used for reference and the product in kind prevail.

This installation manual is only for installing the ceramic parts. For the tank trim or seat & cover installing, please refer to relative manual.

All the installation program must strictly comply with local bathroom and buliding regulation.

PREPARATION

- Carefully check and inspect your new product if it is in good condition and accessories are completed.
- In order to install properly, please refer to product dimensions and check installation dimensions.
- If you have an old toilet, please turn off the water first, then remove the old toilet and clean the ground. If you are install a new toilet, please turn off the water and clean the ground.
- The length of supply hose can not less than 450mm.
- If not install the new toilet immediately, please block the waste pipe with clean items, that is in order to prevent something fall into the waste pipe.
- The ground should be smoothly, otherwise, it may be cracking after install the toilet.
- The unit is millimeter by default, if the drawings are not indicate.
- The components which is mark with imaginary line are installed in the drawings.

⚠ WARNING: FRAGILE PRODUCTS, HANDLE CAREFULLY.

⚠ WARNING: USING CEMENT TO FIX THE TOILET IS PROHIBITED.

- Water efficiency reference sheet, standard: GB25502-2017
39075001, Water per flush: 3/4.8 L, Water efficiency grades: 1 Grade.
- 39310000, Water per flush: 3/4.8 L, Water efficiency grades: 1 Grade.
- 39119001, Water per flush: 3.5/5 L, Water efficiency grades: 1 Grade.

IMPORTANT CONSUMER INFORMATION

- Do not use harsh abrasives or caustic cleansers to clean fixture surface. A mild detergent, warm water, and a soft cloth will remove normal dirt and soap accumulations from fittings and surfaces. Rinse thoroughly after cleaning and polish with a soft dry cloth to restore original luster of material.
- Do not bump the ceramic with great force to prevent it from damaging and leaking.
- Do not use the product in the water below 0°C.
- If the water level in the tank is less than the standard, it will affect the flushing effect.
- When the water pressure is big, please turn the inlet valve down suitably, otherwise the water supply hose will drop down.
- If you live in a hard water area, make certain that the holes in the toilet rim are kept clean to ensure proper bowl flushing. Toilet leaners should be used at least once a week. Use a long-handled brush to clean the rim holes, and to clean as far into the trap as possible to prevent mineral deposits from forming.
- Install the seat & cover according to seat & cover user manual.
- Dimensioning diagrams are provided for each model. DImensions are nominal and may vary within the range of manufacturing tolerance.

⚠ Do not use cleansers in tank. Products containing chlorine (calcium hypochlorite) can seriously damage fittings inthe tank. This damage can cause eakage and property damage. Grohe shall not be responsible or liable for any tank fitting damage caused by the use of cleaners containing chlorine (calcium hypochlorite).

⚠ Please do not use hard materials(like scouring pad)to clean product surface, especially the product logo.

⚠ Please leave more than 24 hours for concretion.

D
☎ +49 571 39 89 333
service.de@grohe.com

A
☎ +43 1 6 80 60
info-at@grohe.com

AUS
☎ 1800 080 055
customer.care@reece.com.au

B
☎ +32 (0)2 899 3077
<https://www.grohe.be/nl/be/onze-service/contact.html>

BG
☎ +359 2 971 99 59
info-bg@grohe.com

BR
☎ 0800 770 1222
falecom@lixilamericas.com

CAU
☎ +99 412 497 09 74
info-az@grohe.com

CDN
☎ +1 888 6447643
info@grohe.ca

CH
☎ +41 44 877 73 00
info@grohe.ch

CN
☎ +86 4008811698
info.cn@grohe.com

CZ
☎ +42 07 21 71 66 73
info-cz@grohe.com

DK
☎ +45 44 65 68 00
grohe@grohe.dk

E
☎ +34 93 / 3 36 88 50
grohe@grohe.es

EST LT LV
☎ +372 661 6354
grohe@grohe.ee

F
☎ +33 1 49 97 29 00
sav-fr@grohe.com

FIN
☎ +358 (09)42451390
grohe@grohe.fi

GB
☎ +44 208 283 2840
info-uk@grohe.com

H
☎ +36 (06)1 238-8045
info-hu@grohe.com

HK
☎ +852 2969 7067
info@grohe.hk

I
☎ +39 2 959401
info-it@grohe.com

IND
☎ 18001024475
customercare.in@grohe.com

IS
☎ +354 515 400
jonst@byko.is

J
☎ +81-3-6748-1180
info_grohe@blisspajapan.jp

KZ
☎ +7 775 007 05 27
service-kz@grohe.com

MAL
☎ 1800 80 6570
customerservice.my@lixil.com

MX
☎ 01 800 839 1200
info@lixilamericas.com

N
☎ +47 22 07 20 70
grohe@grohe.no

NL
☎ +31(0) 88-0030700
<https://www.grohe.nl/nl/onze-service/contact.html>

NZ
☎ +64 09 573 0490
sales@robertson.co.nz

P
☎ +351 234529620
comercial-pt@grohe.com

PL
☎ +48 (22) 5432640
biuro@grohe.com

RI
☎ 0800-1-047-643
customercare-indonesia@lixil.com

RO
☎ +40 021 212 50 50
info-ro@grohe.com

ROK
☎ +82 2 1588 5903
info-singapore@grohe.com

RP
☎ +63 2 89288000
service_center@wilcon.com.ph

RUS
☎ 8 800 200 00 49
service-ru@grohe.com

S
☎ +46 771 14 13 14
grohe@grohe.se

SGP RC
☎ +65 6311 3611
grohe@connectcentre.sg

SK
☎ +420 (2) 77004192
info-sk@grohe.com

T
☎ +6629014455
grohe-thailand@lixil.com

TR
☎ +90 216 441 23 70
groheturkey@grome.com

UA
☎ +380 (44) 5375273
info-ua@grohe.com

USA
☎ +1 800 4447643
Grohetechcare@lixil.com

VN
☎ (+84) 1800 6624
cshk@lixil.com

AL BIH HR KS ME MK SLO SRB
☎ +385 1 2911470
adria-hr@grohe.com

CY M IL GR
☎ 800 11111
info@grome.com

UAE Q KWT BRN OM PK
☎ +971 4 4214557
grohedubai@grome.com

KSA RL JOR IRQ
☎ +966 11 4551667
groheksa@grome.com

ET MA DZ TN

NGR
☎ +202 226147988/98
grohecairo@grome.com

Far East Area Sales Office:
☎ +65 6311 3600
info@grohe.com.sg

Latin America:
☎ +52 818 3050626
info@lixilamericas.com