



Buy it for looks. Buy it for life.®

Specifications

PRODUCT DESCRIPTION

- Manual exposed urinal flushometer with brass angle stop valve
- Cast brass construction with chrome electroplated finish
- Chloramines resistant seals
- G1/2 IPS inlet supply
- G1/2 top spud
- High back pressure vacuum breaker

OPERATION

- Operating pressures: 0.2 - 0.75Mpa

STOP VALVE

- G1/2 IPS vandal resistant control stop
- Solid brass with chloramines resistant face seal

STANDARDS

- Third party certified by IAPMO and CSA to meet ASME A112.19.2M and all applicable requirements referenced therein and complies with requirements of ASSE 1037

WARRANTY

- Warranted for 5 years against material or manufacturing defects



Urinal Flush Valve
Model: 90013

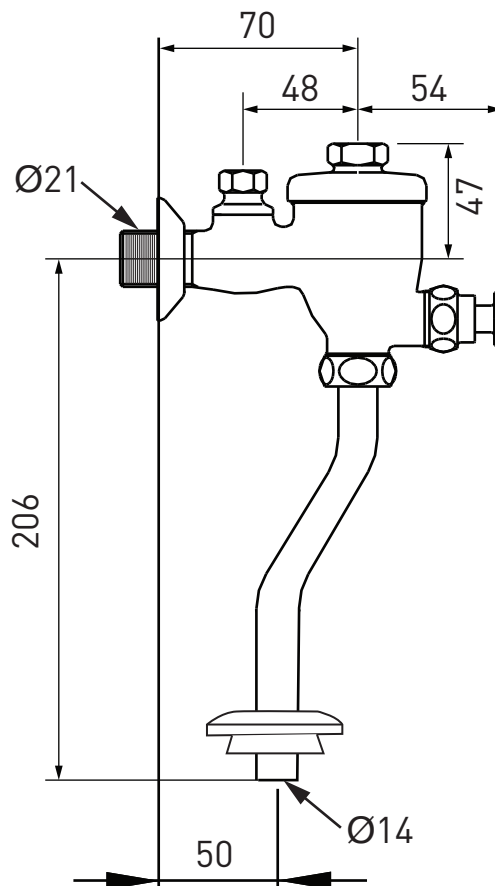

CRITICAL DIMENSIONS

[DO NOT SCALE]